



**IN-LINE TYPE
FIBER OPTIC CLOSURES
SPECIFICATION**

GJS-303



Instruction Manual

Table of Contents

1. General Introduction.....	2
2. Specification.....	2
3. Structure.....	2
4. Installation instructions.....	4
5. Operation procedure.....	4
6. Installation.....	11
7. Main technique data.....	11
8. Packing, transportation, storage.....	12



1. General Introduction

GJS-305 is designed to seal without screws. The compact size and flip-over cover bring easy operation as well as complete function. The splice trays are jointed with a hinge at one side, which makes the operation in each tray easier. It is designed to prevent from operation damage.

2. Specification

Dimension (mm)	380×245×130	Max. capacity(Single fiber)	16
Weight (kg)	4.5~5	Sealing type	Mechanical
Cable ports	1 input cable port for un-cut cable from diameter from 10~17.5mm. 2 output cable ports for cable diameter from 8~17.5mm. 16 output cable ports for cable diameter less than 4mm.	Single splice tray capacity(Single fiber)	16
Splice tray quantity	2pcs		

3. Structure

3.1 Closure and accessories



3.2 Parts list

3.2.1 Main kits

S/N	Description	Quantity	Note
1	Lid	1	337(L)×242(W)×63(H)mm.
2	Base	1	
3	Sealing ring	1	Box sealing
4	8202 sealing parts	16	Sealing cable ports
5	Splice tray	4	For cable splicing and storage
6	Splice tray cover	1	
7	Splice tray bandage	1	Fixing several splice trays
8	Fastener bolt	2	Fixing lid and cover of closure
9	Buckle	4	Fixing lid and cover of closure
10	Tight nuts	16	Sealing soft cable ports
11	Tight tool	1	Special for tight the nuts
12	Cable fixing panel	1	Fixing un-cut cable
13	Adaptor installation panel	4	An adaptor panel for 6 SC simplex adaptors
14	Splice tray bracket	1	Install 4 splice trays
15	Top cover stopper	1	Limit top cover
16	Plastic nuts	2	Fixing cable

3.2.2 Standard parts

S/N	Description	Quantity	Note
17	Wall mounting kit	1	For wall mounting
18	Expansion anchor bolt	2	Parts of the wall mounting kit
19	Hexagon bolt	2	Parts of the wall mounting kit
20	Nylon tie (3*120mm)	12	Fixing cable
21	Fusion sleeve(Φ 1.0*60mm)	According to the fiber cores.	Cable splicing
22	0.2m coil tube	1	Protect the fiber
23	Insulation tape	1	Accessorial fixation
24	0.5m EVA tube	1	Protect fiber
25	Drier	1	
26	M6 internal hexagonal wrench	1	Tool to open the box
27	14# grommet	2	For cable dia. From 12-17.5mm
28	41# grommet	2	For cable dia. From 8-12mm
29	Plastic plug	4	Seal the cable port
30	Iron spanner	1	Tool

3.2.3 Optional parts

S/N	Description	Quantity	Note
25	Pole mounting kit	1	For pole mounting
26	Valve	1	Testing sealing performance

4. Installation instruction

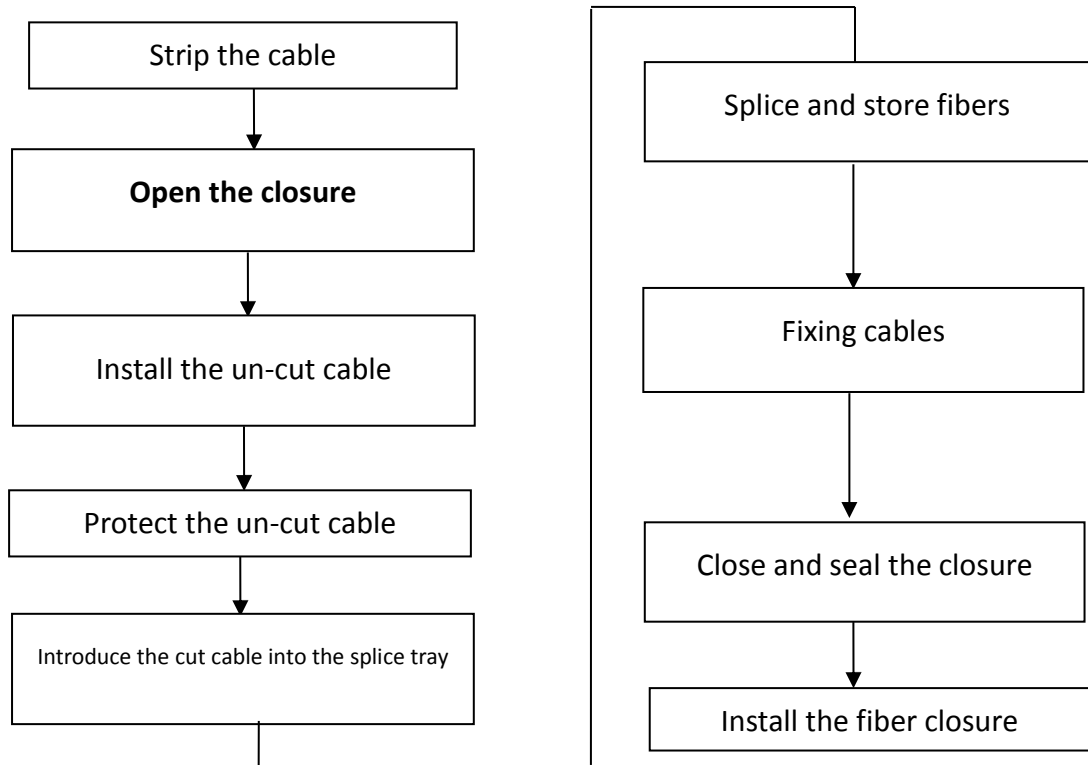

5. Working procedure

5.1 Check up

5.1.1 (1) Check the item number and accessories of fiber closure. (2) Check the fiber specification. (3) Check the parts quantity. (4) Check the instrument. (5) Tools as below picture (Picture 2) .

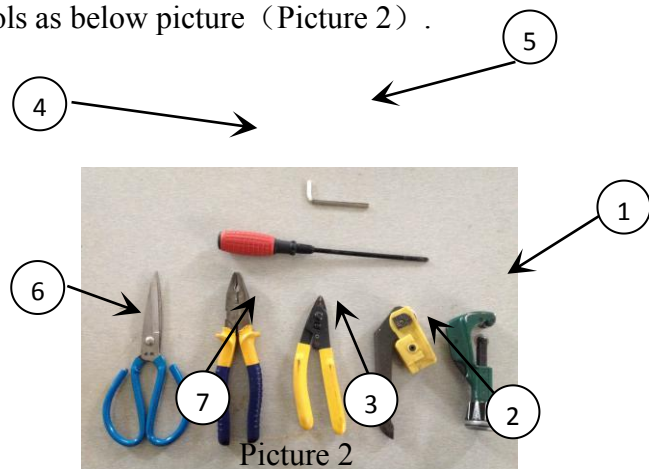

1. Transverse cutting knife for cable outer security layer.
2. The longitudinal open cable knife.
3. Steel core cut clamp.
4. Cross screwdriver.
5. M6 hexagonal socket wrench.
6. Scissors.
7. Cutting clamp

5.2 The procedure to strip the cable fiber

5.2.1 Mark the cut point on the cable according to the different length requirements.

5.2.2 Strip the cable outer layer.

5.2.3 The requirement for stripping the un-cut cable.

- (1) The length should be no less than 2000mm;
- (2) Cut the steel core at the length of 50mm of the cable cut point.

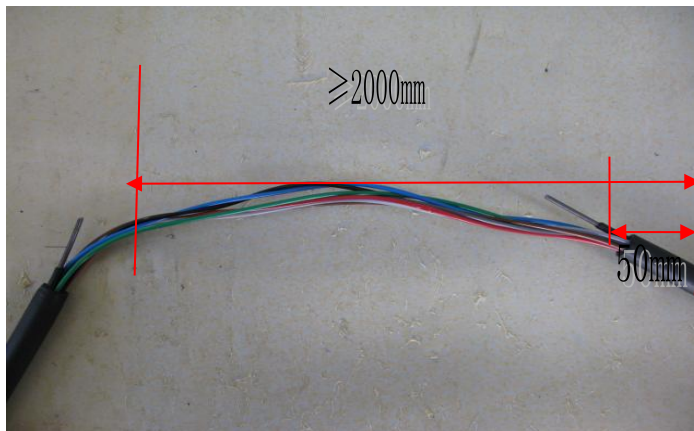

5.2.4 The requirement for stripping the cut cable.

- (1) The length should be no less than 1000mm;
- (2) Cut the steel core at the length of 50mm of the cable cut point.

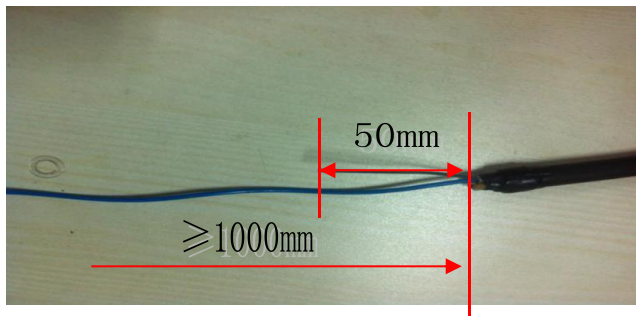

Note: ① Be sure not to damage fiber. ② Do not use any damaged cable.

5.3 Open the closure

5.3.1 Use the tool to pry buckles. (Picture 4)

5.3.2 Open the lid, take out the accessories. (Picture 5)



Picture 4



Picture 5

5.3.3 In order to prevent the closure lid falling down when installation, take out the block from the splice tray installation bracket and put the block as below picture(Picture 5-1).

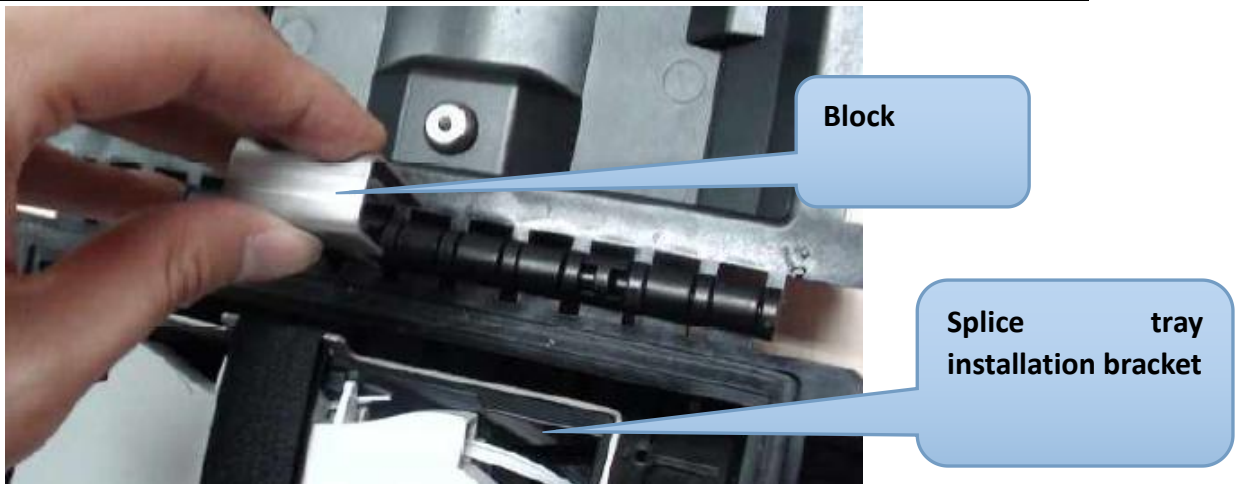

Picture 5-1

5.4 Un-cut cable and branch cable working procedure

5.4.1 Remove the plastic nuts and take out the cable sealing components as below pictures.(Picture 6/7/8)



Picture 6



Picture 7



picture 8

5.4.2 Cut the grommet to pass through the un-cut cable.(As picture 9-1 and picture 9-2)



Picture 9-1



Picture 9-2

5.4.3 Split the other two components, according to the sequence to install the un-cut cable mounting components. (As picture 10)

5.4.4 After the cable passing through the ports into the box, tighten the hose clamps, fixing cable. (As picture 11)



Picture 10

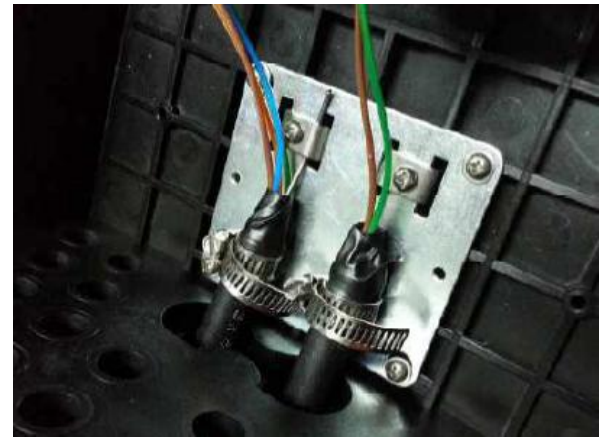

Picture11

5.4.5 Fix back the the briquetting of the input port. (As picture 12)



Picture 12

5.4.6 Use EVA tube to protect the bare fibers and winding the stripped cable by insulation tape as below pictures. (Picture 13)

5.4.7 Cable get through in turn the plastic nut, washer, grommet, washer as below picture(picture 14), then install to the closure port.

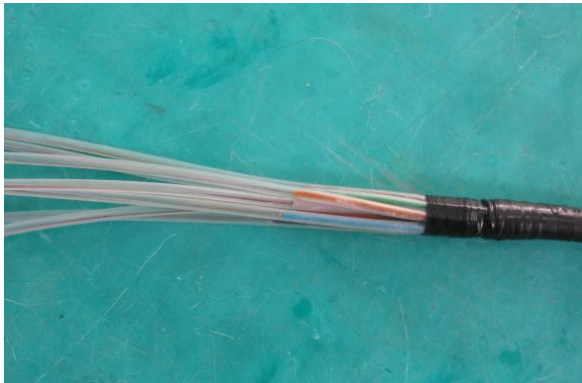

Picture 13



Picture 14

5.4.8 After the cable get through the closure, tight the hose clamp and fix the steel core of cable.

5.4.9 Then tight the plastic nut as picture 15.

5.4.9.1 If no cable get through the cable ports, use plastic plug to seal the grommet as picture 16.



Picture 15



Picture 16

5.5 Clear up the cable routing

5.5.1 Protect the bare fiber by coil tube and clear up the cable. (As picture 17)

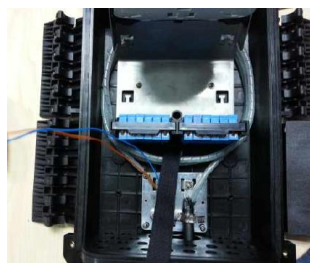

Picture 17

5.6 Introduce the cut cable into the splice tray

5.6.1 Protect the bare fiber by coil tube and clear up the cable, then introduce into the splice tray. (As picture 18 and picture 19)



Picture 18

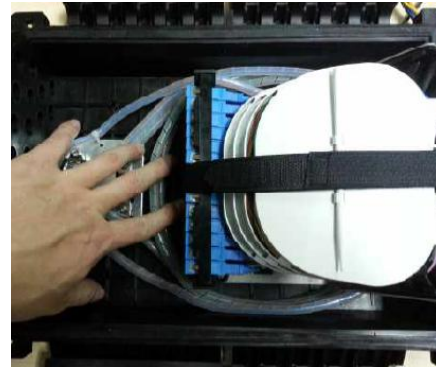

Picture 19

5.7 Fiber splicing process.

5.7.1 Introduce the fiber into the splice tray.

5.7.2 Splicing the fibers.

5.7.3 Put in the fusion sleeve into the splicing holder accordingly.

5.7.4 Use the tool to coil, storage the balance fibers.(As picture 20 and picture 21)

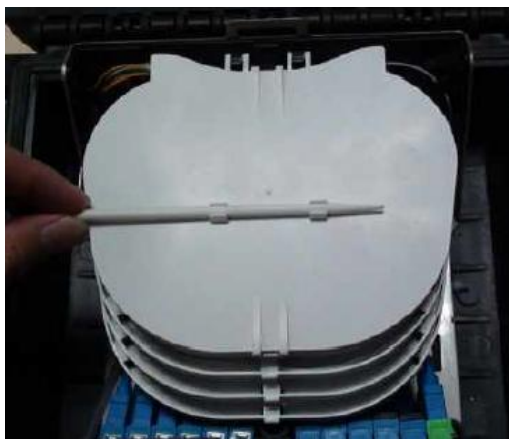

Picture 20

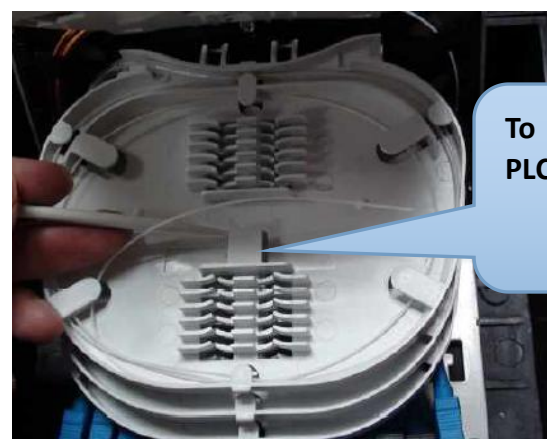

Picture 21

5.7.5 Cover the splice tray cover and put back the tool on the tray cover.

5.8 Soft cable port working procedure

5.8.1 First insert the white parts of soft cable into the plastic nut, then move the plastic nuts to the black parts of the soft cable, then assemble the sealing components to the soft cable as below pictures and put in the pigtail to the closure ports and connect to the SC adaptors. (Daub the grease on the sealing grommet if feels hard to insert the cable).

Note: The plastic nut only for cable diameter less than 4mm to insert.

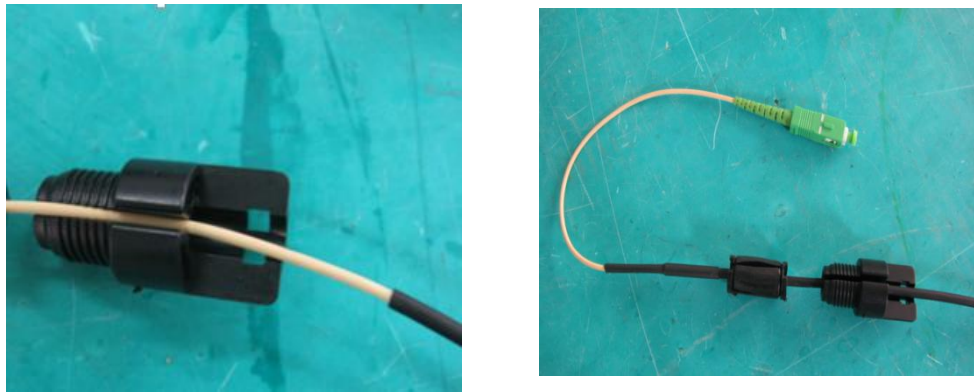

Picture 22

5.8.2 Tighten back into the closure ports.(As picture 23)

5.8.3 After tighten the bottom of the cable bolts, use the nylon tie to tie the cable for fixing cable. (As picture 24)



Picture 23



Picture 24

5.9 Close the fiber closure

5.9.1 Close the closure and close the four buckles, also tighten the bolts.

(As picture 25).

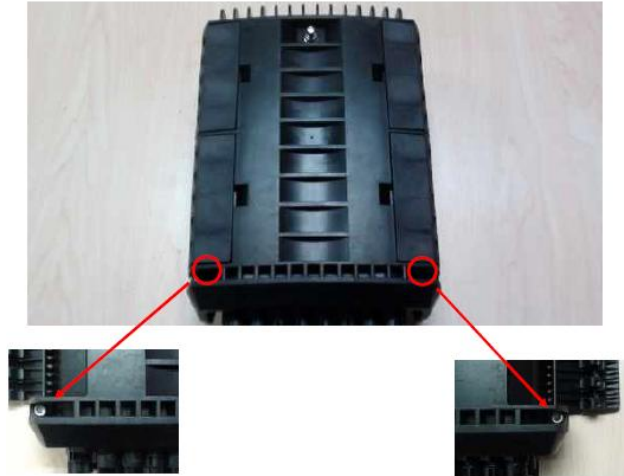

Picture 25

6. Installation

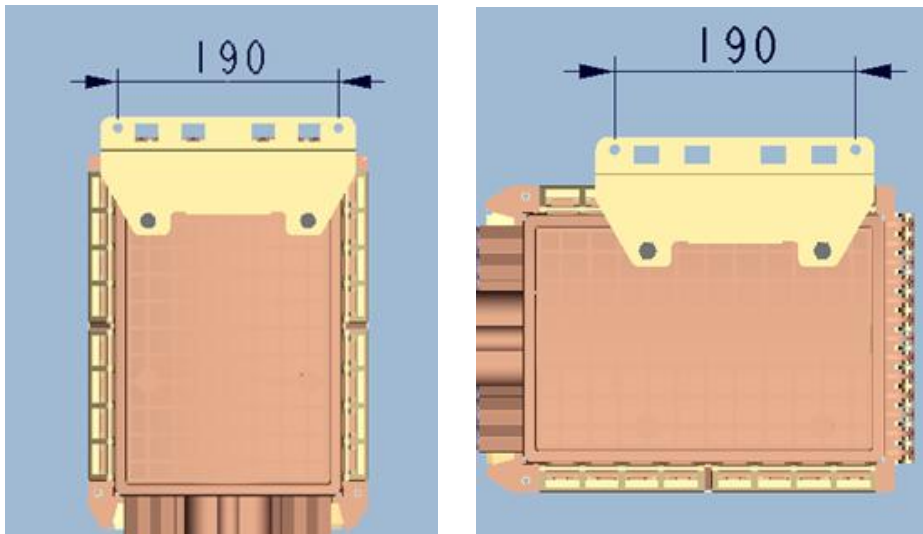

Wall mounting

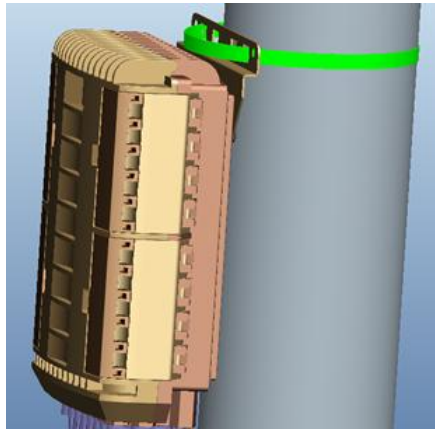

Pole mounting

7. Main technical data.

- 7.1 Environmental temperature: $-40^{\circ}\text{C} \sim +65^{\circ}\text{C}$
- 7.2 Optical performance: No significant additional attenuation.
- 7.3 IP68

8. Packing, transportation and storage

- 8.1 This equipment packaging is moisture-proof and earthquake-proof. The accessories are packed first plastic bags, then into the boxes with plastic bags for sealing. There are moisture-proof and earthquake direction signs outside the boxes.
- 8.2 It can't be inverted in the transport and be free from rolling when carrying. Please load carefully and prevent the collision. You should prevent it from heavy rain before installation. The temperature in the transport should be controlled between -35°C to $+55^{\circ}\text{C}$.
- 8.3 The excessive accumulation of goods should be stored on the cartons. The treasury should away from the erosion of corrosive gas equipment and the temperature should be below 45°C and higher than -5°C , and relative temperature should not be high in long-term (generally less than 75%).